

SOLAR PUMP KIT USER'S MANUAL

Designed for fountains & ponds
Item No.: XCSP-200L/H

1. OVERVIEW

- 1) The solar pump is designed for outdoor or indoor fountain use, and is powered by a solar panel. In order to make full use of solar energy, the solar panel needs to be placed in the sunlight with its solar cells facing the sun as much as possible.
- 2) The pump operates at its full performance when the solar panel generates more power than it demands, the output power of the solar panel depends on sunlight intensity and the incident angle at which sunlight strikes the panel surface.
- 3) The latest DC brushless motor technology such as locked rotor protection and overheat protection is introduced in the pump design and manufacturing, so that the pump has high efficiency and long service life.
- 4) The pump flow rate can be adjusted by the flow valve (referring to the right figure).

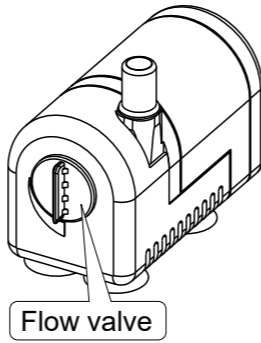

2. COMPONENTS

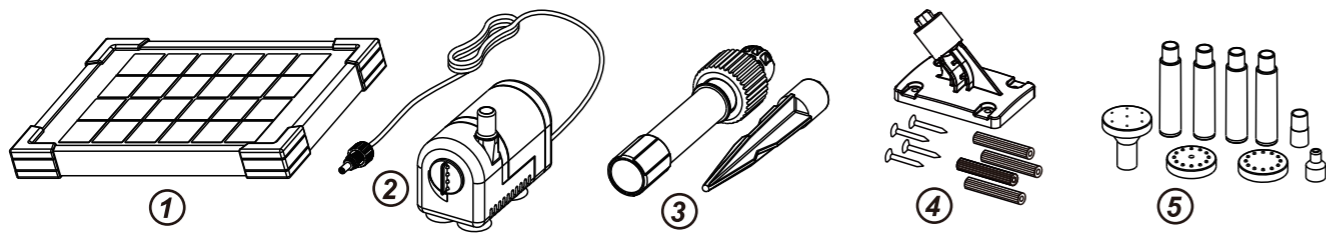

1) Solar panel 2) Pump 3) Ground spike 4) Wall bracket 5) Fountain nozzle accessories

3. ASSEMBLING

- 1) Unpack all components carefully.
- 2) To install the solar panel on the ground, find a sunny place that is shadow-free all day long and install the solar panel by the ground spike.
To install the solar panel on walls, wooden fences or other vertical planes, fix the wall bracket onto the vertical plane with screws as shown in the below figures. If the solar panel can't stand steadily, tighten the joint at the back of the panel.

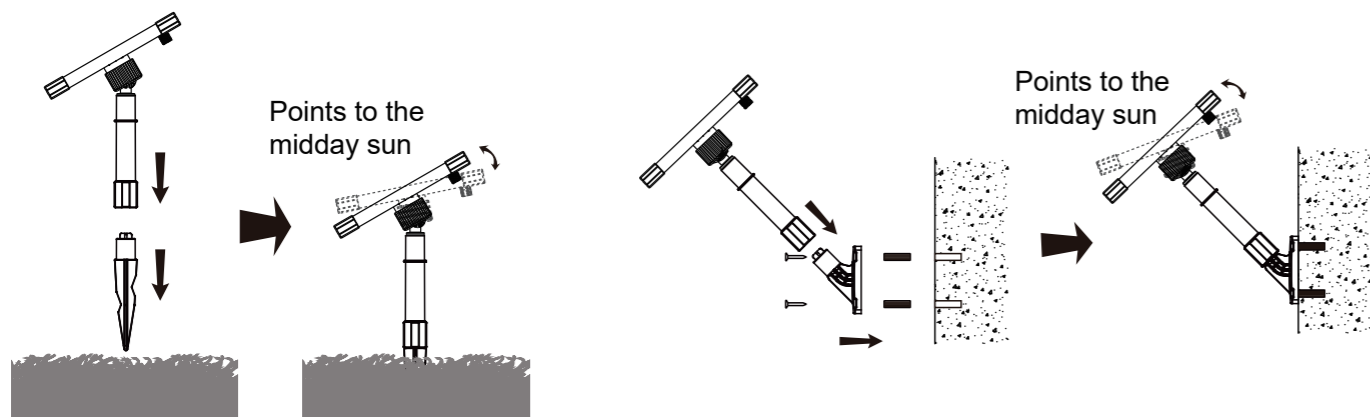

- 3) For the application of pumping a small water feature, install the pump as per the instruction given by the relevant party.
- 4) For the application of pumping a spray fountain, install the pump following the steps below:
 - a) Pick one of the 4 fountain nozzles and join it with a proper number of extension tubes. The nozzles available can produce 4 different spray patterns.
 - b) Install the extension tube supported fountain nozzle onto the pump outlet with the help of the tube adapter.
 - c) Fix the pump at the bottom of a small shallow pond or a feature pool etc. It is best to keep the pump off the pond base to avoid drawing the pond waste into the pump which will eventually develop into pump blockage. Use an underframe or similar to elevate the pump.
 - d) To maximize the visible fountain spout length, the fountain head should be positioned just above the water surface by using the extension tubes as shown in the below figure. If these 4 pcs of extension tubes are all used and the fountain head is still immersed in the water, please uplift the pump body somehow.

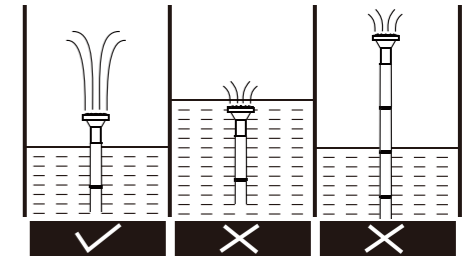
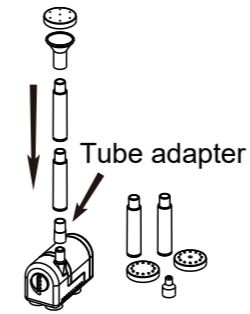

- e) The sizes and shapes of different spray fountains are shown as below:

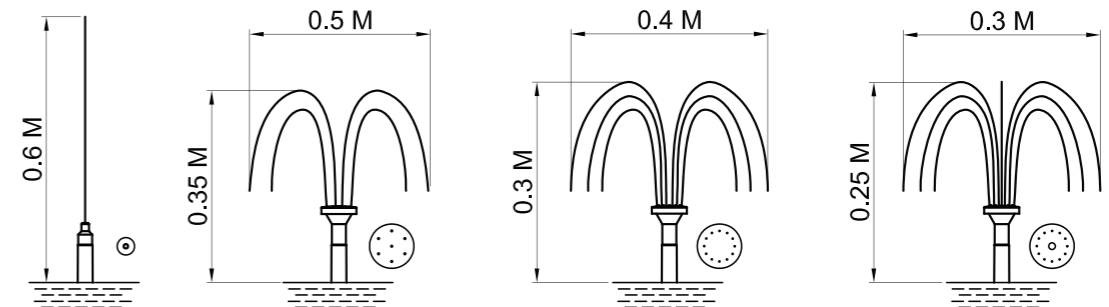

- 5) The solar pump is now ready to work. Please make sure to keep the pump fully underwater, then electrically connect the pump to the solar panel and tighten the screw for water protection.

4. CAUTIONS

- 1) Do not connect the pump to any AC power supply directly; it's ONLY for DC power.
- 2) Operate the pump in water only (never above 40 °C), especially keep it away from flammable liquids.
- 3) Do not let the pump run dry, make sure to keep the pump fully underwater while the pump is operating.
- 4) Any altering of the product itself or changing of the components voids warranty.
- 5) When water starts to freeze in winter, take the pump out of water and store it in a frost-free room. The water frozen may cause damage to the plastic parts.

5. CLEANING AND MAINTENANCE

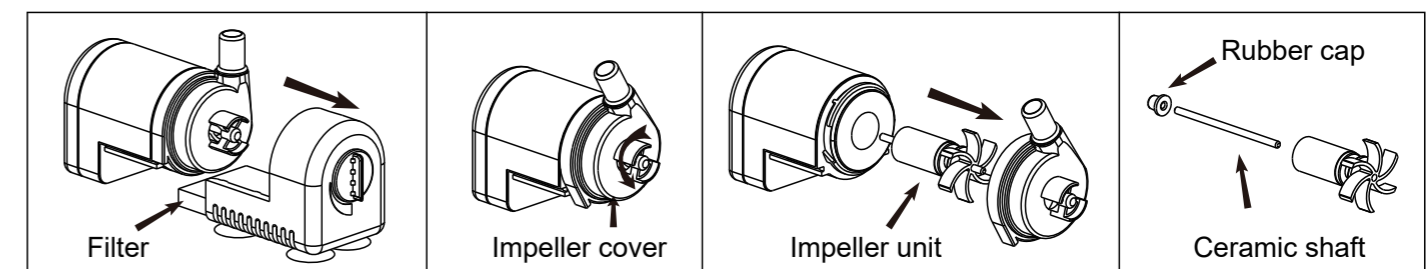

If the pump starts losing power or stops working after operating for a certain time, please clean the pump following the steps below (See the above figures for demonstration):

- 1) Electrically disconnect the pump.
- 2) Press on the bottom of the filter housing, and at the same time, move the filter housing apart from the pump.
- 3) Turn the impeller cover clockwise to the end and then carefully pull the impeller cover together with flow valve apart from the pump.
- 4) Remove the impeller unit from the pump.
- 5) When needed, dismantle the impeller unit carefully.
- 6) Wash every part to clean the debris.
- 7) Assemble the pump in reverse sequence.
- 8) Electrically connect the pump.

***Clean the surface of the solar panel when necessary to keep it working at full performance.**

6. TROUBLE SHOOTING

*Pump does not operate even though the solar panel is in full sunlight.

- 1) No or bad connection to the solar panel—check and reconfirm the connection to the solar panel.
- 2) Impeller is blocked—clean the pump as described in “**CLEANING AND MAINTENANCE**”.

*Pump does operate but there is no water running through the tubes: Clear the tubes, filter and pump filter housing to make sure they are through completely.

7. TECHNICAL DATA AND PUMP CURVE

Operating voltage	6 V
Power of solar panel	2.5 W
Max. pump power	0.9 W
Max. water lift height	0.7 M (2.3 FT)
Max. flow rate	200 L/H (53 GPH)
Cable length	5 M (16.4 FT)

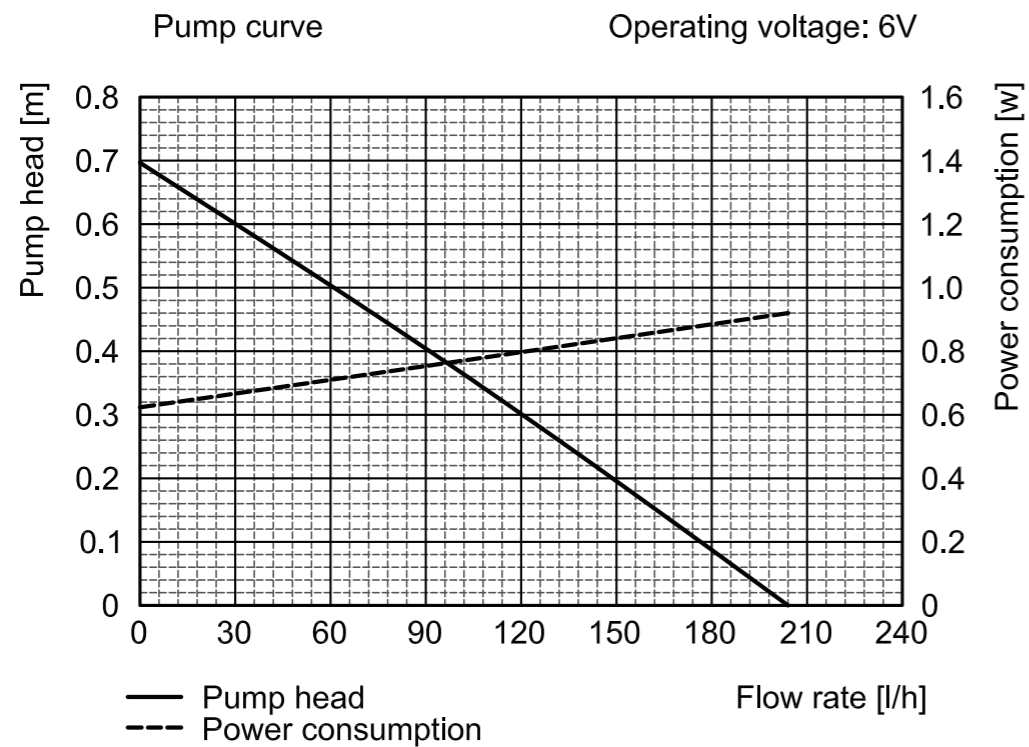

CONTACT US

South Africa

www.waterhouse.co.za

Phone: +27 (0)11 466 8250

Email: shop@waterhouse.co.za

